

PITCHING INSTRUCTIONS

Your tent includes:

- 1 x Frame Set
- 1 x Canvas
- 1 x Canvas Fly (11 x guy ropes attached)
- 52 x Pegs
- 7 x Ropes (5 x single ropes, 2 x 'V' ropes)

1. Select a dry, level site and clear any sharp objects that may puncture the floor. Remove the tent from its carry bag, untie fabric ties and unroll the tent.

2. Take the frame parts bag and carefully tip out the poles. Group the poles together in to the following pole groups:

- | | |
|--------------------------------------|---------------------------------|
| Side Wall Assembly Poles: | Parts: #1, #18/#8, #1 (2 Sets) |
| Centre Ridge Pole: | Parts: #2/1, #181#8, #1 (1 Set) |
| End Support Poles: | Parts: #5, #4 (3 Sets) |
| | Parts: #48, #SB (1 Set) |
| External Centre Ridge Upright Poles: | Parts: #32, #33 (2 Sets) |
| Internal Centre Ridge Upright Pole: | Parts: #6/2, #7/3 (1 Set) |
| Support Poles: | Parts: #6/3, #34, #35, #358, |
| | #34, #6/3 (1 Set) |
| Porch Poles: | Parts: #50, #51, #10/2 (1 Set) |
| | Parts: #14, #13 (1 Set) |
| | Parts: #42B, #42 (2 Sets) |
| | Parts: #41B, #41 (4 Sets) |
| | (Extra set for side awning) |

The poles are coded with a number on a coloured sticker for easier assembly. The green poles are along the bottom (green for grass), the blue poles are the upper level poles (blue for sky) and the red poles are the porch poles.

Although the stickers should last well, it is a good idea to label the poles with the same coloured insulation tape and a permanent marker for future reference.

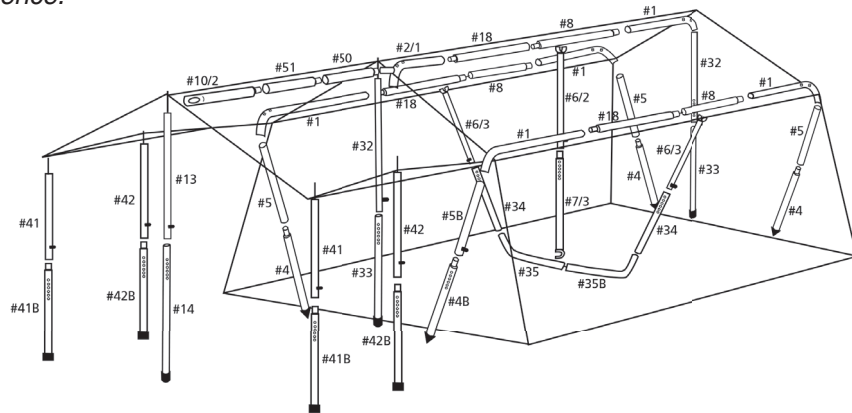

3. Roll the tent out and move it into the desired position. Ensure each side is pulled taut. Peg the four corners out first, then the middle pegging loops on each side, then proceed to peg out the remaining pegging points.

To keep the porch clean and out of the way, fold it back over the roof of the tent until needed.

To make sure the tent stays in place insert the pegs into the ground at a 45° angle, not straight down.

Unzip and open all of the doors and windows to make erecting the tent easier.

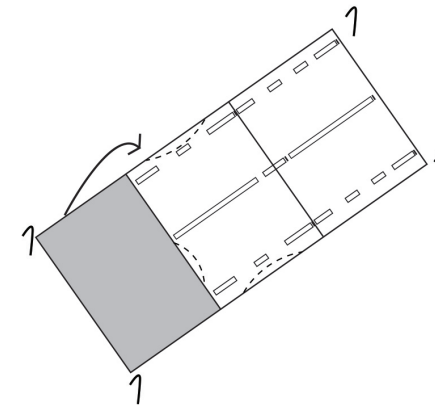

4. SIDE WALL FRAME ASSEMBLY:

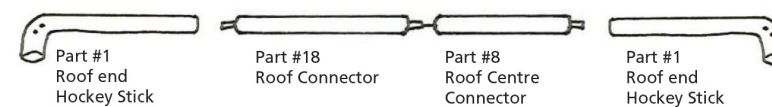

5. A) From the porch end of the tent, insert Part #1 through the elasticised gusset sock (looks like a sleeve) and webbing loop and through the pole sleeve, feed part #8/#18 through sleeve and connect to part #1.
B) Take second Part #1 and follow same process at the back of the tent. Feed Part #8/#18 through sleeve and attach. Repeat for the other side.

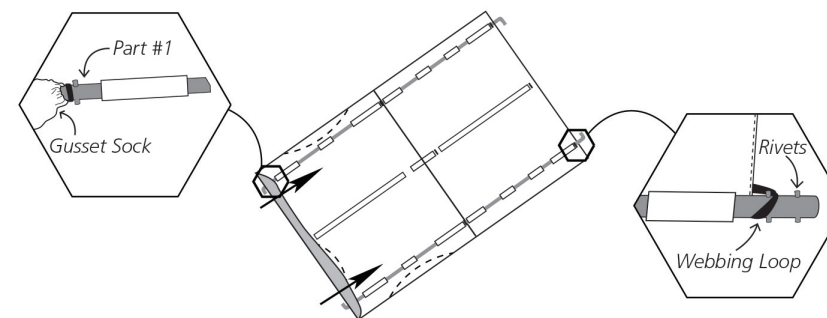

6. While the tent is still lying on the ground, the CENTRE RIDGE can be assembled. Connect Part #2/1 to Part #18/#8.

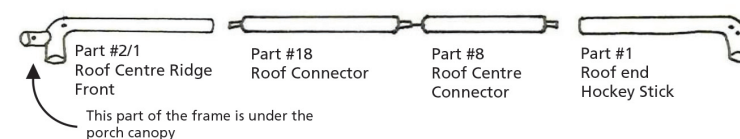

7. Insert the pole through the gusset sock, from underneath the porch canopy through to the top and then through the pole sleeve along the ridge, towards the rear of the tent. Tie the elastic loop at the front of the tent around Part #2/1. Connect Part #1 to the end of Part #8 and ensure the webbing loop fits over the rivets securely. Also check that the pole sleeve hasn't caught when the poles have been pushed together. Check that all poles have been threaded through any webbing loops on all three frame assembly's.

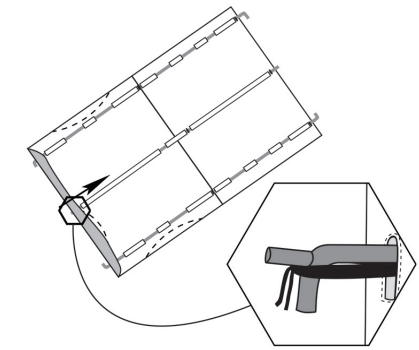

8. Fitting the fly: carefully lay the fly on top of the tent and attach the Velcro loops to the corners of the tent frame. Clip the buckle into place on at the front.

9. Connect parts #5 and #4 (3 sets) together and connect Part #4B to #5B. These will create the END SUPPORT LEGS needed below.

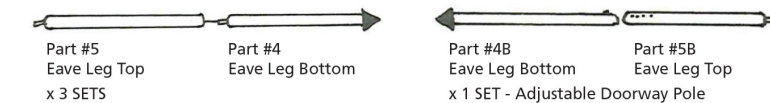

10. Insert the connected END SUPPORT LEG poles into the roof ends and raise the sides of the tent. This will take two people to do effectively. Raise the front entrance first.

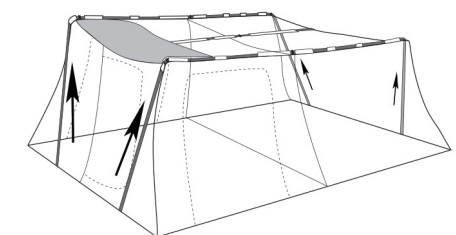

11. Connect part #32 to Part #33 (2 sets) to make the EXTERNAL CENTRE RIDGE UPRIGHT poles.

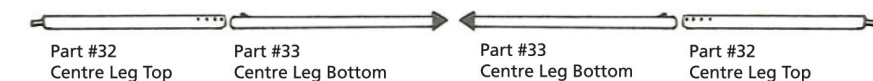

12. Place the EXTERNAL CENTRE RIDGE UPRIGHTS into place at each end and lift the roof until taut, use the dome clip buttons to adjust to the appropriate height so the tent fabric is taut.

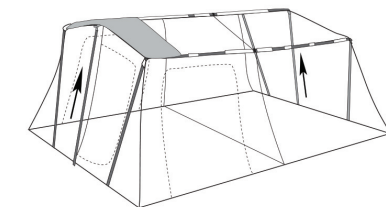

13. Refer to the Support Pole Configuration Diagram below. Go inside the tent and find the slot in the top of the wall seam, approximately 10cm in front of the room dividing wall, and clip Part #6/3 onto the SIDE WALL ASSEMBLY pole outside, through this opening. Assemble the remaining poles as the support pole configuration diagram shows. Adjust these, using the dome clip buttons until the SIDE WALL ASSEMBLY poles are not bending when viewing from the outside.

Support Pole Configuration Diagram:

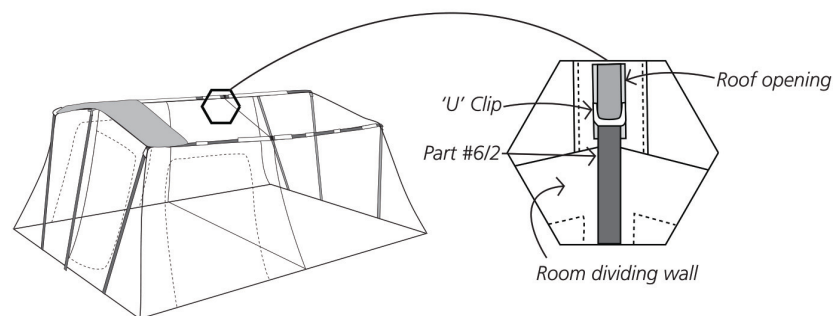
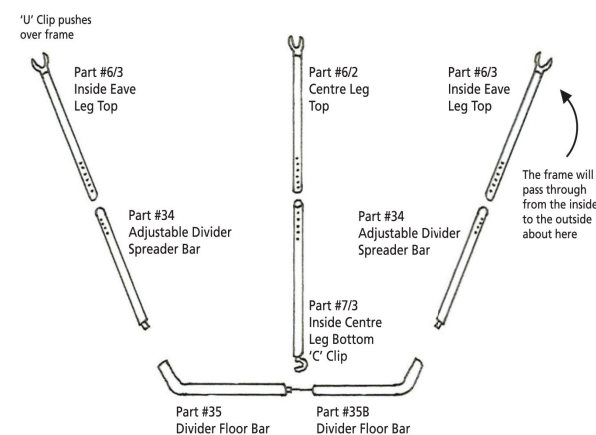

14. Clip the top 'U' clip, on the INTERNAL CENTRE RIDGE UPRIGHT pole (Part #6/2), onto the exterior ridge pole by placing it through the opening in the fabric roof ridge seam [approx 10cm forward of the room divider curtain]. Attach the 'C' clip at the bottom of the centre pole to Part #35/#35B. Attach Part #7/3 to Part #6/2 and adjust, using the dome clips, until the pole is firmly in place and the ridge line is level when viewing from the outside.

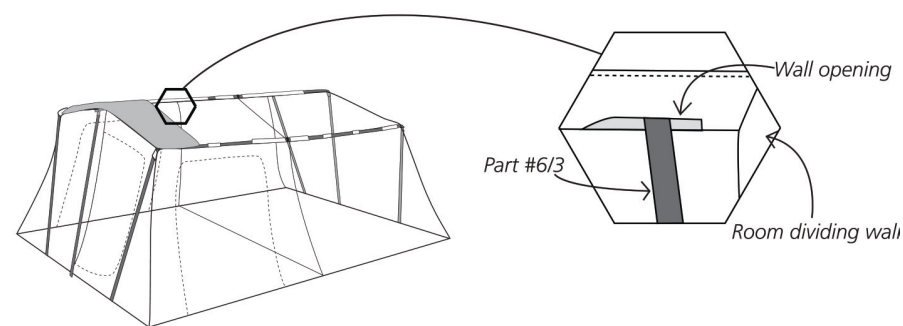

15. Assemble the porch ridge pole (#10/2, #51, #SO) and connect to the opening in Part #2/1 at the centre of the front of the tent. Carefully, pull the porch canvas out over the assembly and vertically place the Porch Centre Pole through the eyelet of Part #10/2 and then the porch canvas. Then guy rope this directly out.

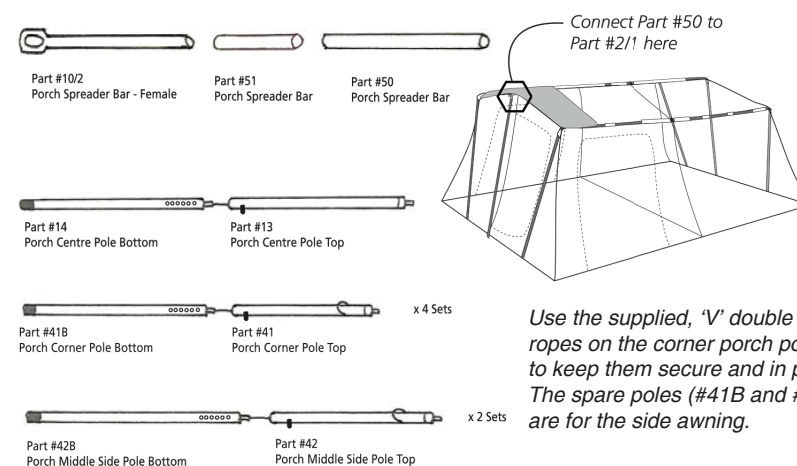

16. Next, connect together the porch corner poles, Part #41 B to #41 and vertically place one at each corner and then guy rope these out securely. Connect Part #41 B to #42 and vertically place through the eyelets in each side of the porch. Securely guy rope these out and peg out the pegging points on the corner legs.

17. ADJUSTING THE FLY

Unvelcro the fly and peg out the four corners of the fly. Ensure that the fly is sitting squarely on the main cabin of the tent. Peg out the rear rope. Finish pegging all the remaining ropes. Ensure that adequate tension has been applied to the rope adjusters to keep the fly sitting securely. Ropes should not be too close to the tent, ie. more angle means more tension.

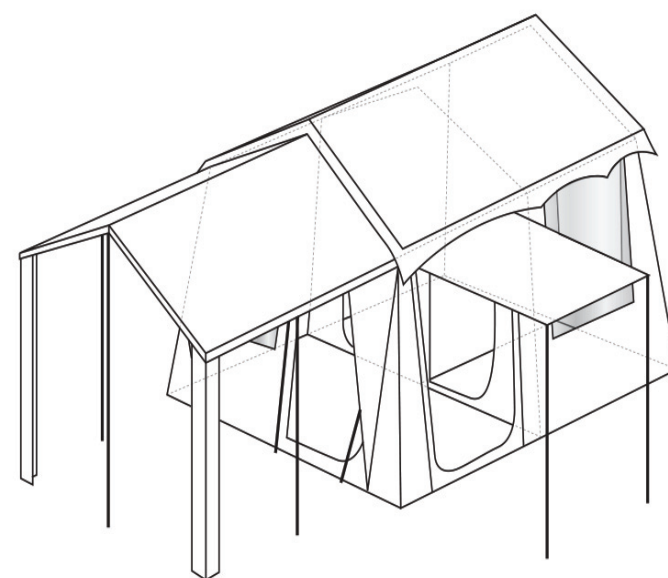

REVERSE THE PROCEDURE TO LOWER THE TENT

TENT CARE INSTRUCTIONS

- Before you use your new tent, fully unpack and pitch it at home. It is important to familiarise yourself with the set up procedure and the various features.
- Ensure you thoroughly pre-weather your tent before use to ensure the longest life for your canvas tent.
- Select a site that is level, clear of any sharp objects, is dry and will drain well if it rains and is protected from wind and other elements.
- For best results, enlist the help of at least one other person to assist in pitching the tent.
- Support frames and canvas should be pulled taut, NOT over-stressed.
- Never pull the pegs out using the canvas. Always use a tent peg remover or claw hammer.
- Please note, the warranty on this tent will be deemed void if the product is used for any purpose other than a temporary shelter.
- Keep clear of overhead power lines and trees when setting up your tent.
- Do not leave the tent exposed to direct sunlight for extended periods. UV light is one of the most damaging elements for your tent.
- Ensure there is an adequate gap between the fly and inner tent to ensure adequate ventilation and to prevent condensation build up.
- Your tent is ventilated for all normal conditions, however condensation may occur in certain circumstances such as being totally closed off in wet or humid conditions and steam caused by cooking. If this does occur, thoroughly air the tent at the first opportunity.
- Make sure when closing doors that you hold the flaps up to take pressure off the zips. Ensure that the tent is never over stretched, especially as this may cause problems with the internal doors. Never store your tent away damp and ensure it is stored in a well-ventilated area, preferably off the floor. Should mildew spots appear, brush them off before they become attached. Mildew damage of any kind is not covered by our guarantee. DO NOT use excess force or other harsh tools to remove soilage from tent.
- Like all assets canvas tents require regular care and attention to give the life and service expected. Regular cleaning with an abundance of clean water and a soft brush, especially after exposure to salt water will preserve your tent's life. Do not allow bird droppings, earth or vegetable matter to remain in contact with the fabric. NEVER USE SOAPS OR DETERGENTS.
- Tents are not fire proof, if exposed to flame or high heat sources they can ignite and burn. Always take care when using spirit or gas appliances such as stoves and lanterns near your tent.
- Some of these products contain chemicals, which can destroy your tents proofing and cause it to leak. Avoid using aerosol sprays and keep petrol, oil, solvents and other similar fluids away from the fabric. Do not use these inside or around your tent as any damage caused by these is not covered by our guarantee.
- Always remember that your tent is made from cloth, and should not be compared with a house. It is waterproof under normal conditions but in severe weather conditions some water may penetrate. If you apply water proofing to your tent check that you are applying the right one for your tent's canvas type.
- Make sure your tent is pitched properly and keep a close eye on the weather, as we have no control over how and where the tent is used or pitched. Extra pegs and ropes are recommended in stormy conditions. Please note, wind damage is not covered by our guarantee. Check and adjust guy ropes and pegs daily.
- Tent fabrics are not 100% colourfast and some fading will occur naturally, however; this does not affect the performance of the fabric. Do not leave your tent up and unattended for extended periods of time. Tents are not designed as permanent dwellings. Tents are guaranteed for normal camping use only.



Distributed by: Aber, Hamilton, NZ
www.kiwicamping.co.nz

3732-11/13